

# SIMDET version 04

## ① Vertex detector

= **CCD** : impact parameter resolutions ✓  
(K.M. : BRAHMS)

C.D. : parametrization  
of CCD (1.0 cm)  
= CCD (1.5 cm)

- **APS** : impact parameter resolutions  
- last week from M.B.

## ① Tracking system

→ fig.

K.M. provided (BRAHMS)

$\left. \begin{array}{l} \bullet \sigma(p_{\perp}) \\ \bullet \sigma(\theta) \\ \bullet \sigma(\phi) \end{array} \right\} \text{pkt}(\theta, p)$

⇒ dips and bumps !

⇒ parametrized ⇒ SIMDET

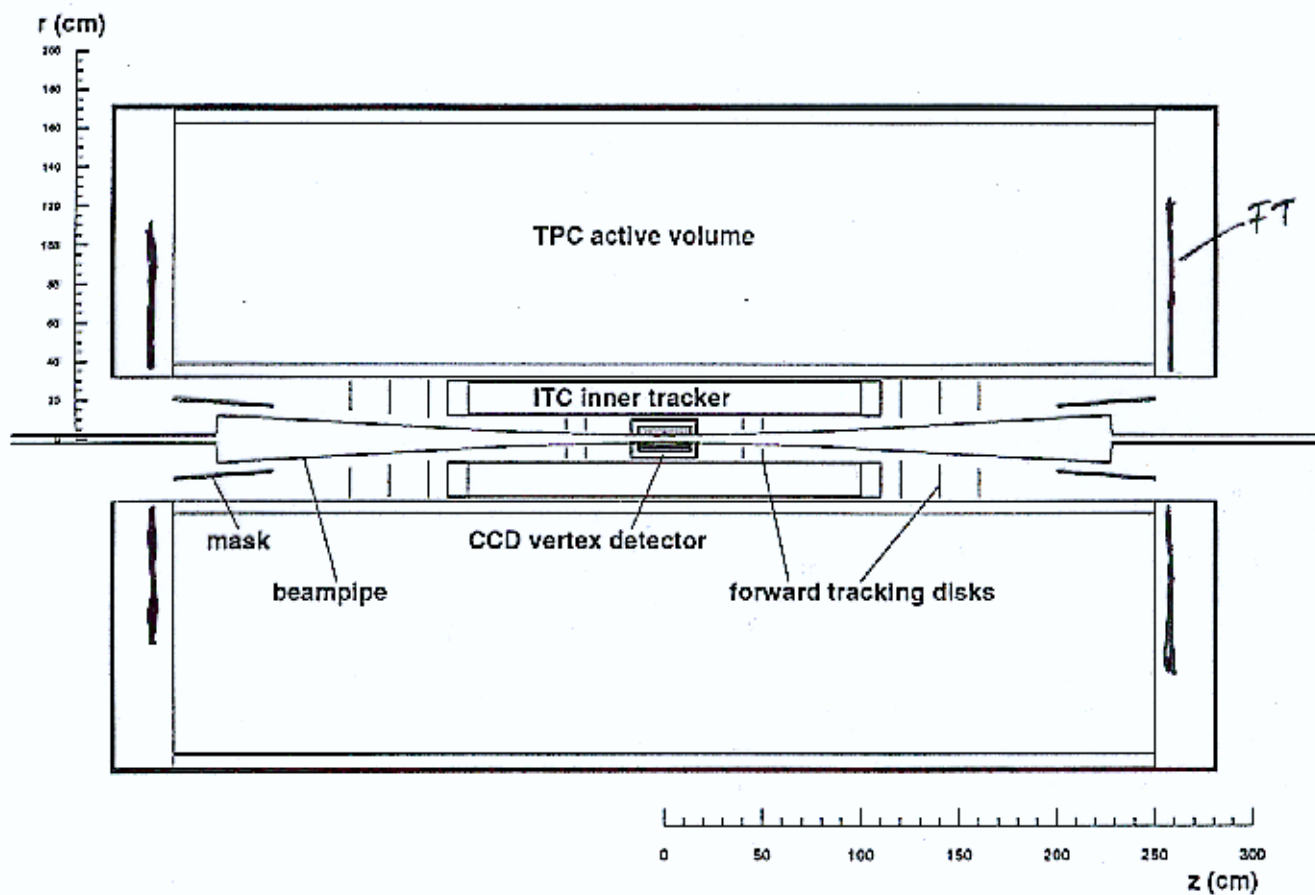

open:

- momentum resolution for low  $p$  ( $\leq 1.0 \text{ GeV}$ )
- Covariance matrix
  - reasonable parametrization?

• calorimeters (ecal/hcal)

Is present status of BRAHMS sufficient for SINDEF? **M.P.!**

[ Are the new ecal/hcal versions significantly better/worse (or approx. equal) than the old ones? ]

→ answer very helpful

① Low angle tagger

( $\theta$ : 24 ... 83 mrad)

→ Fig.

From N.T.

→ some (marginal) info's

→ muons

→ ( $e^\pm/\gamma$ )



② Fast lumi detector

no single particle information

③ Particle identification,  $dE/dx$

M. H → provided code

problem:

reliability due to  
double hit / track

# Mask Design

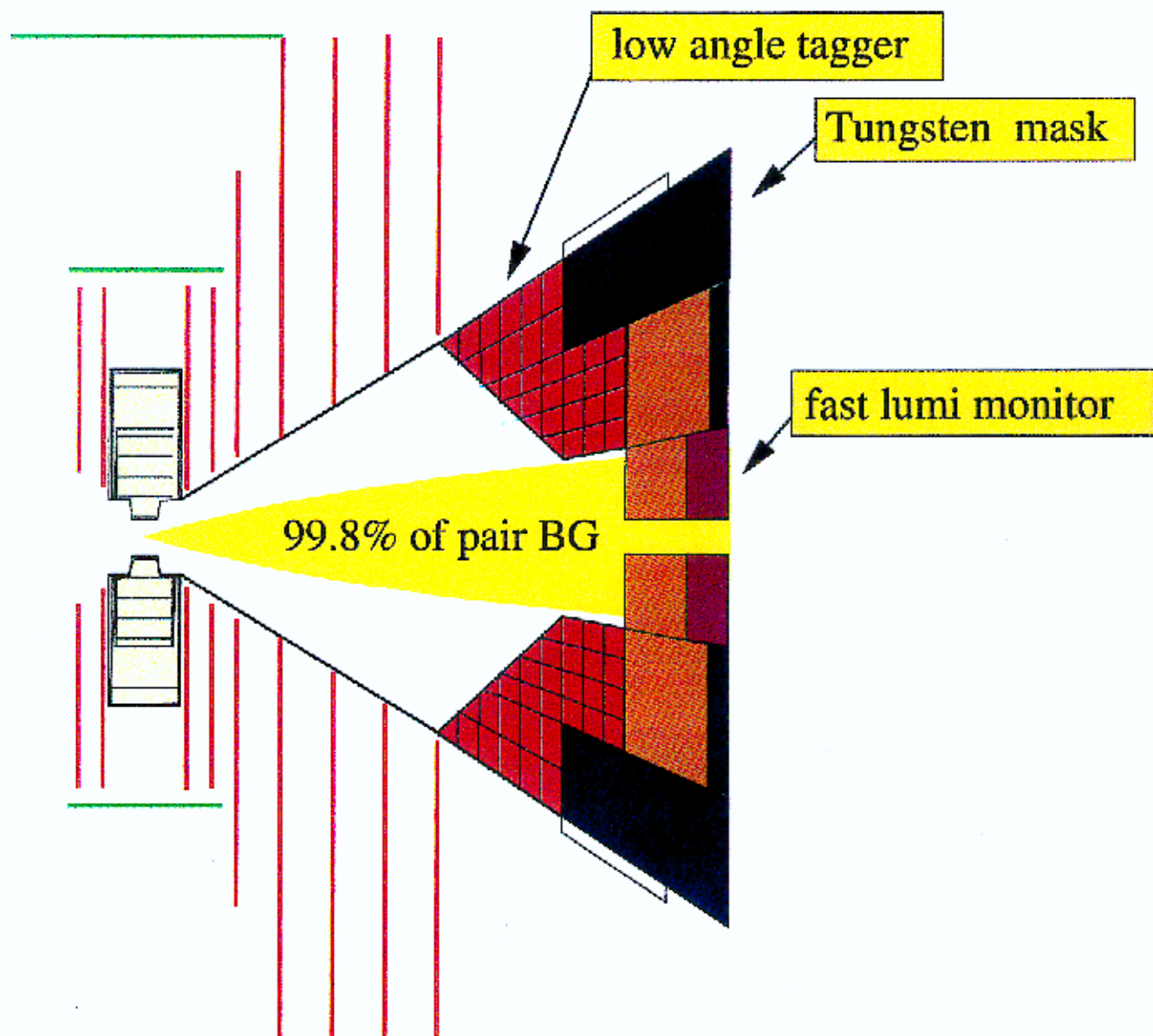

detector	lower acceptance [mrad]	upper
fast lumi monitor	3.85	23.5
low angle tagger 1	23.5	39.5
low angle tagger 2	39.5	55.5
low angle tagger 3	55.5	83.1

① Bohm's Theorem

if  $\psi$  is a CIRCULAR (T.O.)

② Event display

H.V.

③ Order of events

## Appendix C: Data cards

Key	Variable	Data type	Meaning
NEVT	NEVENT	INTEGER	total number of events to process (D=10)
PYTH	IFPYTH	INTEGER	1 = event generation by <u>PYTHIA</u> , 0 = no <u>PYTHIA</u> generation (D=1); <b>D=2: beam strahlung</b>
EVTI	IFEVTI	INTEGER	1 = event reading from an external file, written by sr LCWRITE, 0 = no event reading (D=0)
GENF	LUNGENF	INTEGER	input file name of generated events, user defined
WDST	IFWDST	INTEGER	1 = event writing to an external file, 0 = no event writing (D=1)
RECF	LUNRECF	INTEGER	output file name of processed events, user defined
FORM	IFFORM	INTEGER	1 = formatted output structure, 0 = unformatted output structure (D=0)
BEST	IFBEST	INTEGER	1 = best estimates are enabled, 0 = no best estimates (D=0)
VECS	IFVECS	INTEGER	1 = filling of the array VECF(I,K) for VECSUB, 0 = no filling of this array (D=0)
HIST	IFHIST	INTEGER	1 = history of the generated event to output file, 0 = only stable generated particles to output file (D=0)
<del>COMP</del>	<del>IFCOMP</del>	<del>INTEGER</del>	<del>1 = event reading from an external file, written by CompHEP, 0 = no event reading (D=0)</del>
APS1	IFAPS1	INTEGER	1 = pixel detector (for 1 cm beam pipe) is enabled, 0 = no pixel detector (D=0)
APS2	IFAPS2	INTEGER	1 = pixel detector (for 2 cm beam pipe) is enabled, 0 = no pixel detector (D=1)
CCD2	IFCCD2	INTEGER	1 = CCD detector (for 2 cm beam pipe) is enabled, 0 = no CCD (2cm) detector (D=0)
CCD1	IFCCD1	INTEGER	1 = CCD detector (for 1 cm beam pipe) is enabled, 0 = no CCD (1cm) detector (D=0)
<del>FWTR</del>	<del>IFFWTR</del>	<del>INTEGER</del>	<del>1 = additional forward tracker is enabled, 0 = no additional forward tracker (D=0)</del>
FWMU	IFFWMU	INTEGER	1 = forward muon detector is enabled, 0 = no forward muon detector (D=0)
LUMI	IFLUMI	INTEGER	1 = luminosity detector is enabled, : <b>Fast lumi monitor</b> 0 = no luminosity detector (D=0)
MASK	IFMASK	INTEGER	1 = instrumented mask is enabled, : <b>Low angle tagger</b> 0 = no instrumented mask (D=0)

VTX:  $\rightarrow$  DCA / 5  
 $\rightarrow$  DCA