

CONTRACT NO.		INFN - PADOVA	
APPROVALS	DATE		
DRAWN M. BETTINI		MAGIC SUM BOARD POWER SUPPLY	
CHECKED			
ISSUED	SIZE A3	FSCM NO.	DWG. NO. MAB01001 v0.0
SCALE		SHEET 1 OF 18	

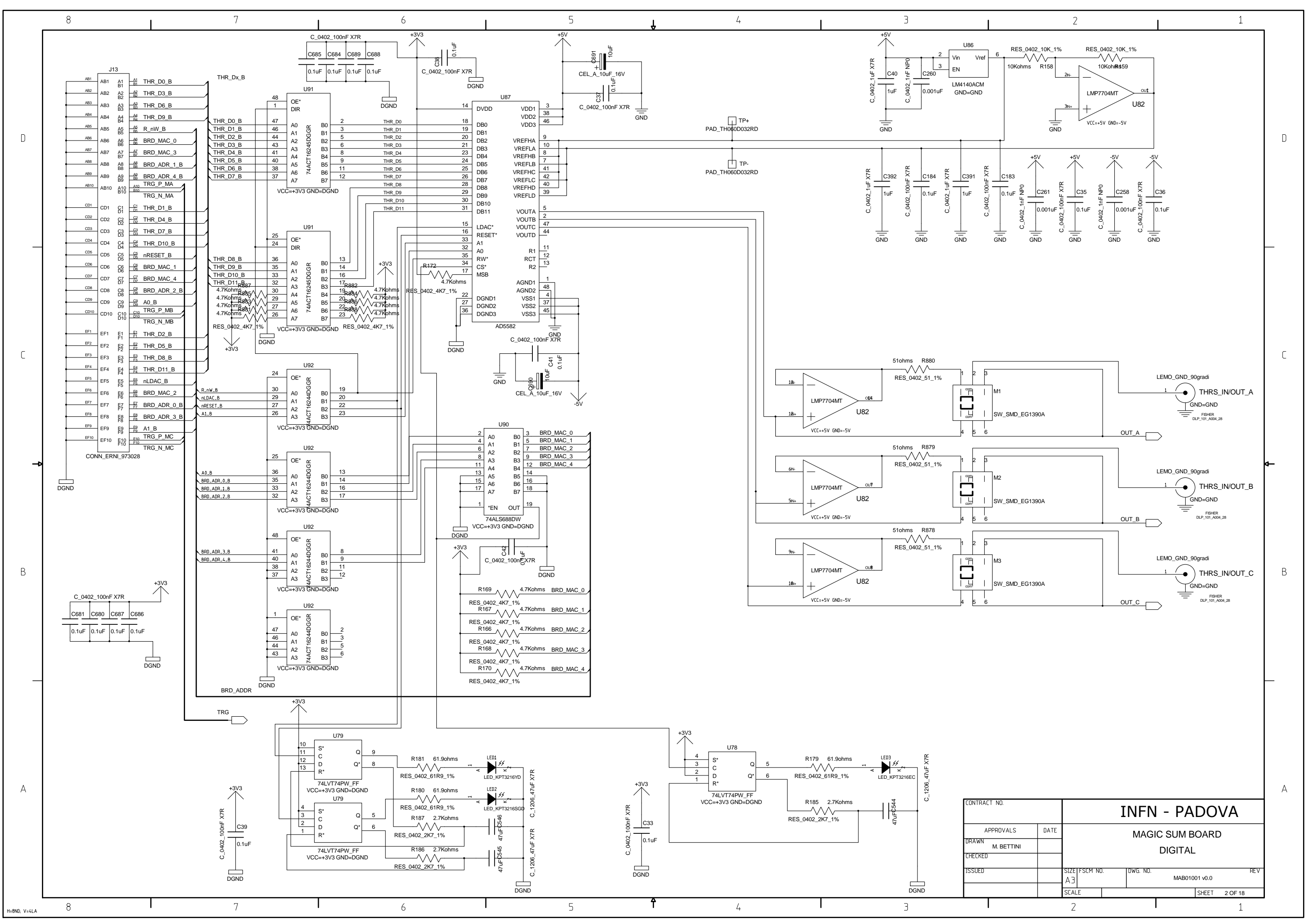

CONTRACT NO.		INFN - PADOVA	
APPROVALS	DATE	MAGIC SUM BOARD	
DRAWN M. BETTINI		DIGITAL	
CHECKED		SIZE A3	FSCM NO. MAB01001 v0.0
ISSUED		DWG. NO.	REV
		SCALE	SHEET 2 OF 18

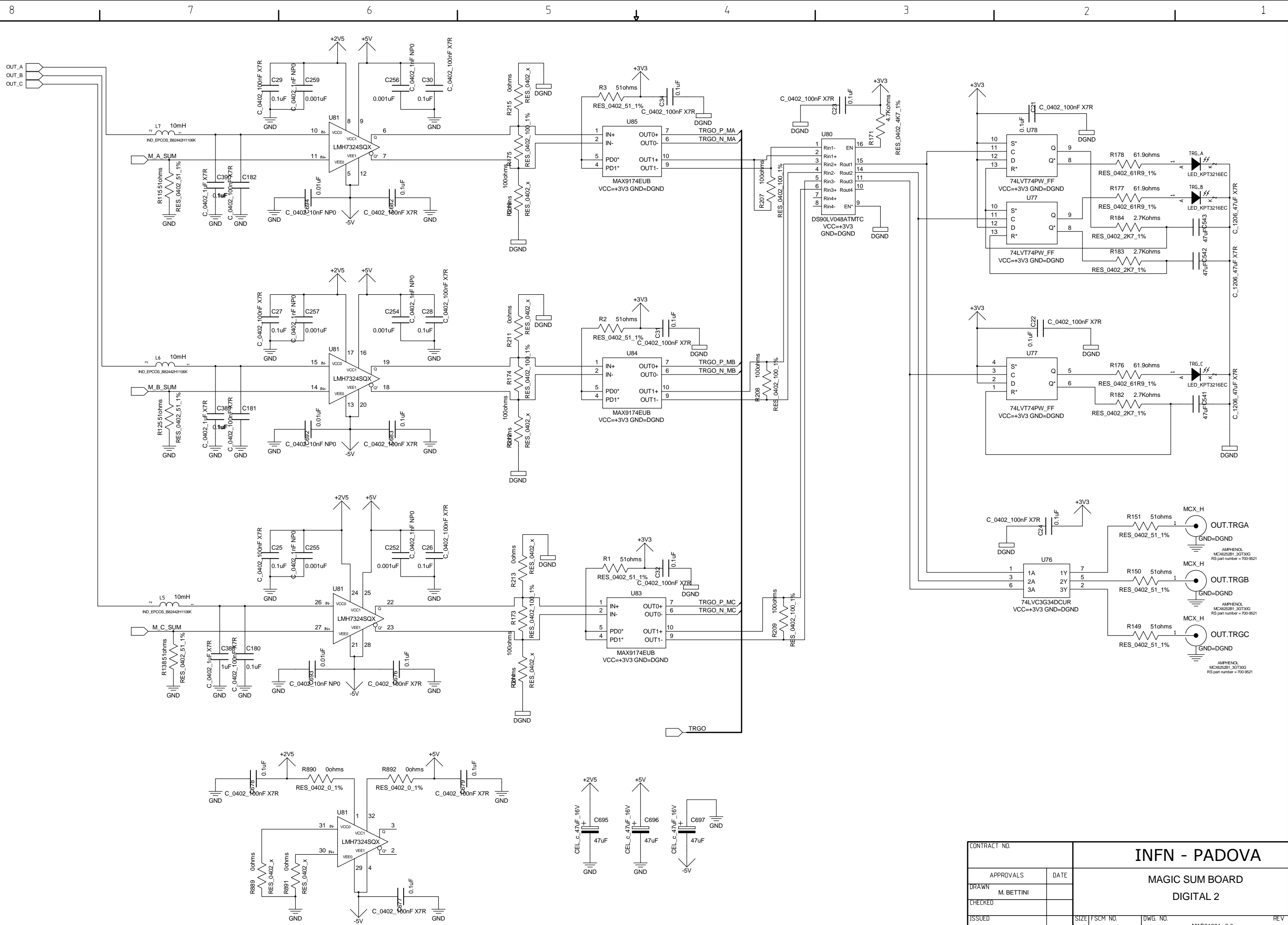

CONTRACT NO.		INFN - PADOVA	
APPROVALS	DATE		
DRAWN M. BETTINI		MAGIC SUM BOARD	
CHECKED			
ISSUED		SIZE A3	FSCM NO.
		DWG. NO.	MAB01001 v0.0
		SCALE	REV
		SHEET 3 OF 18	

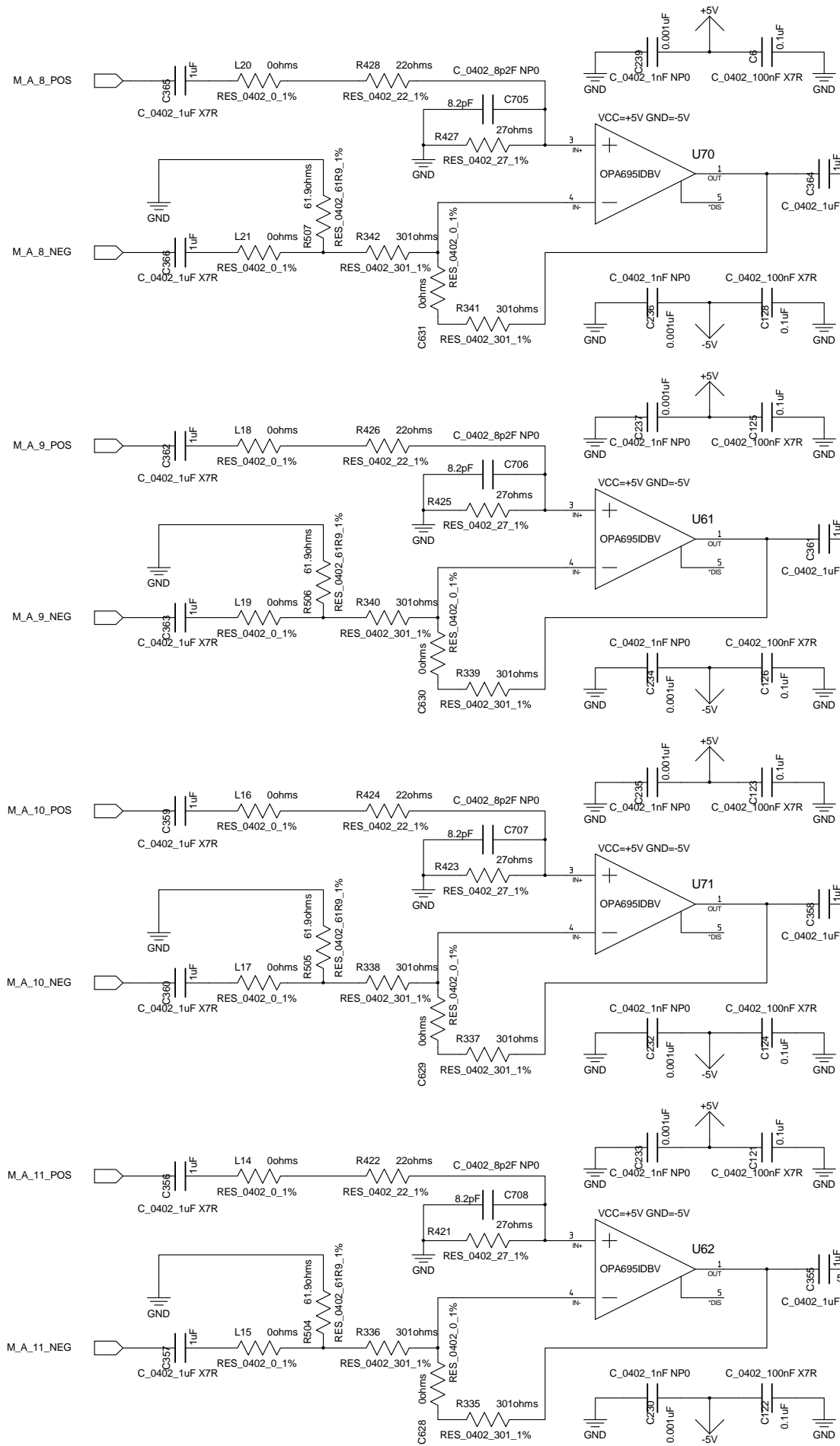

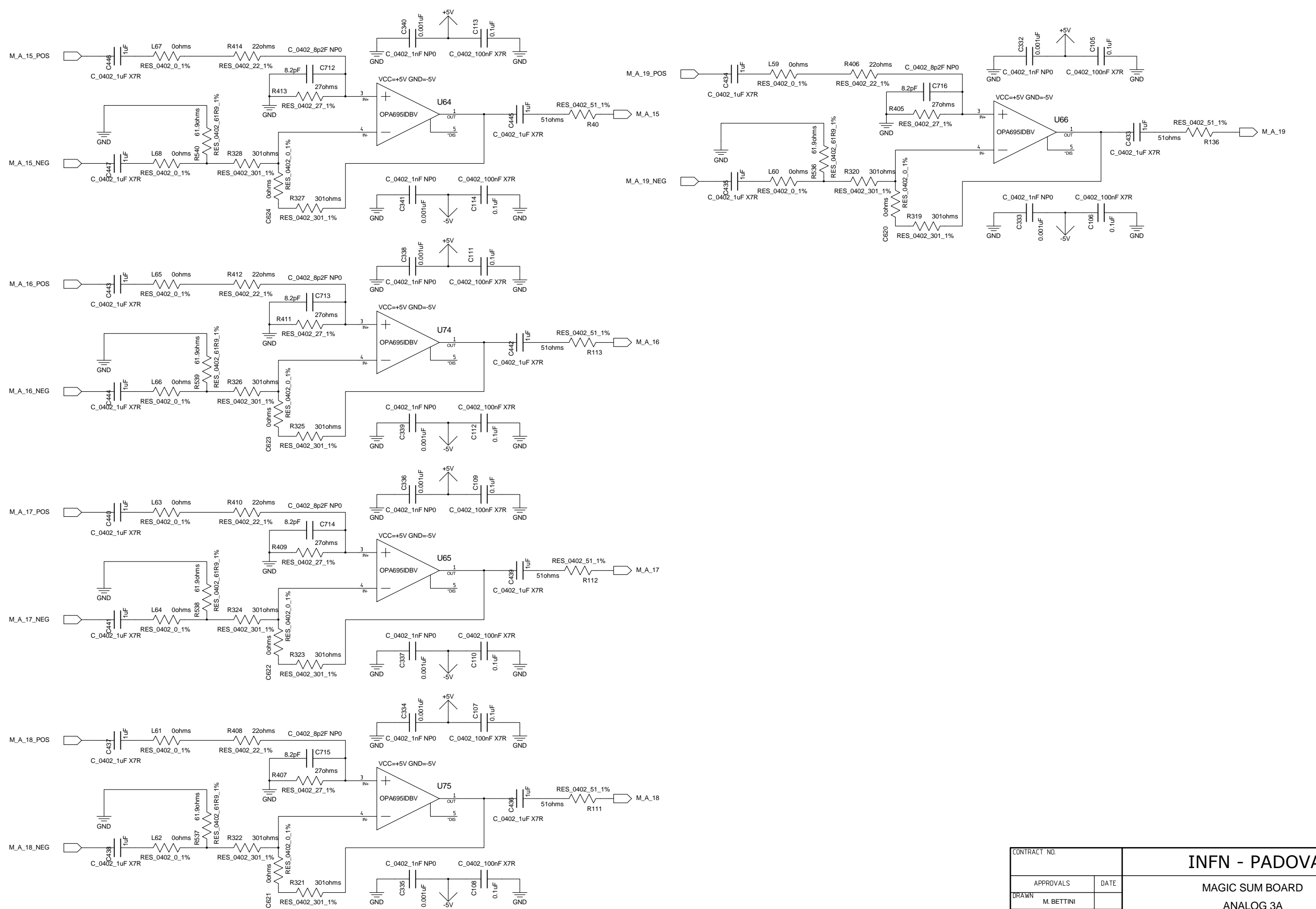

CONTRACT NO.		INFN - PADOVA MAGIC SUM BOARD ANALOG 3A	
APPROVALS	DATE		
DRAWN	M. BETTINI	SIZE	FSCM NO.
CHECKED		DWG. NO.	MAB01001 v0.0
ISSUED		SCALE	REV
		SHEET 6 OF 18	

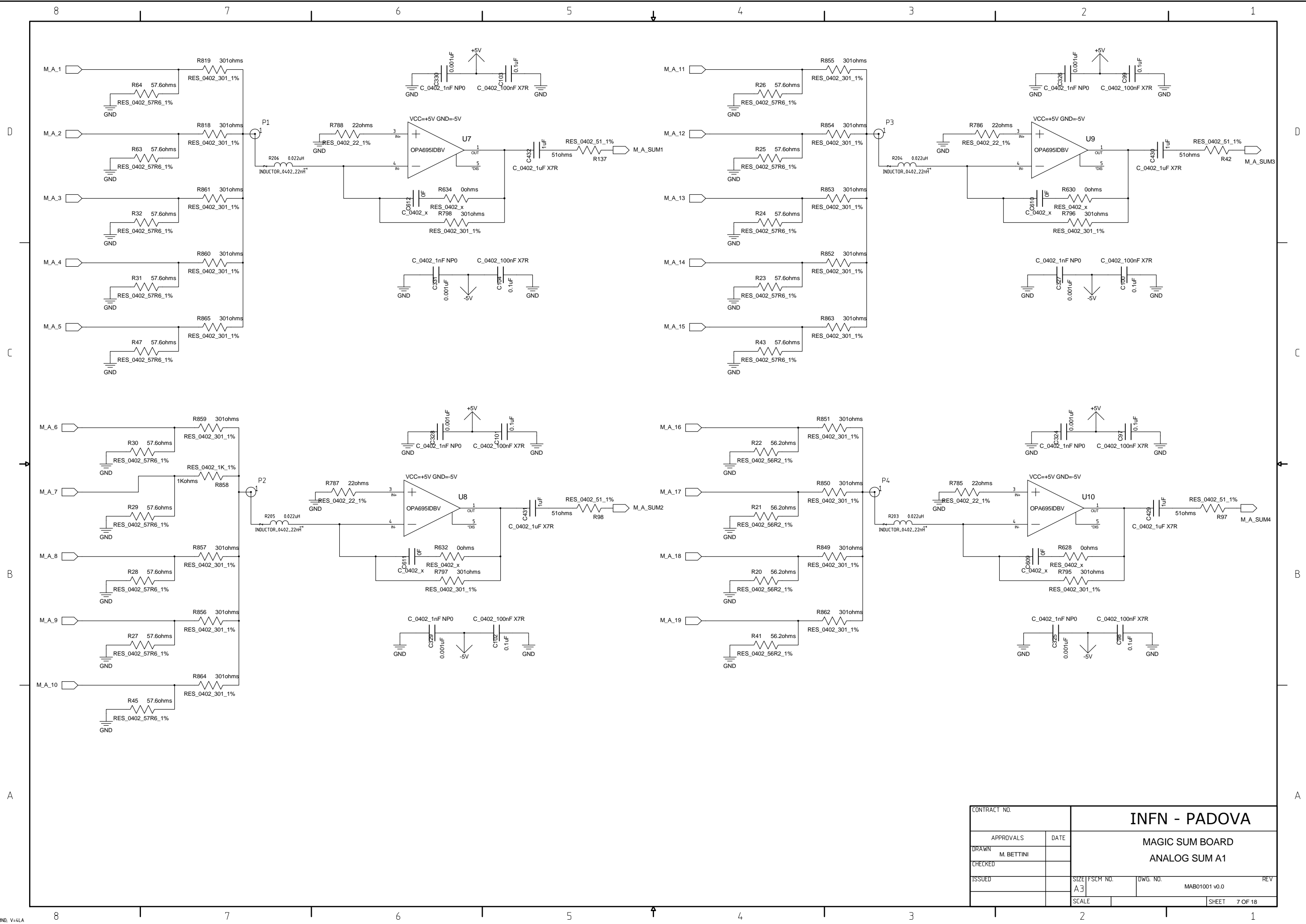

CONTRACT NO.		INFN - PADOVA			
APPROVALS	DATE				
DRAWN	M. BETTINI	MAGIC SUM BOARD			
CHECKED					
ISSUED		SIZE	FSCM NO.	DWG. NO.	REV
		A3		MAB01001 v0.0	
		SCALE		SHEET	7 OF 18

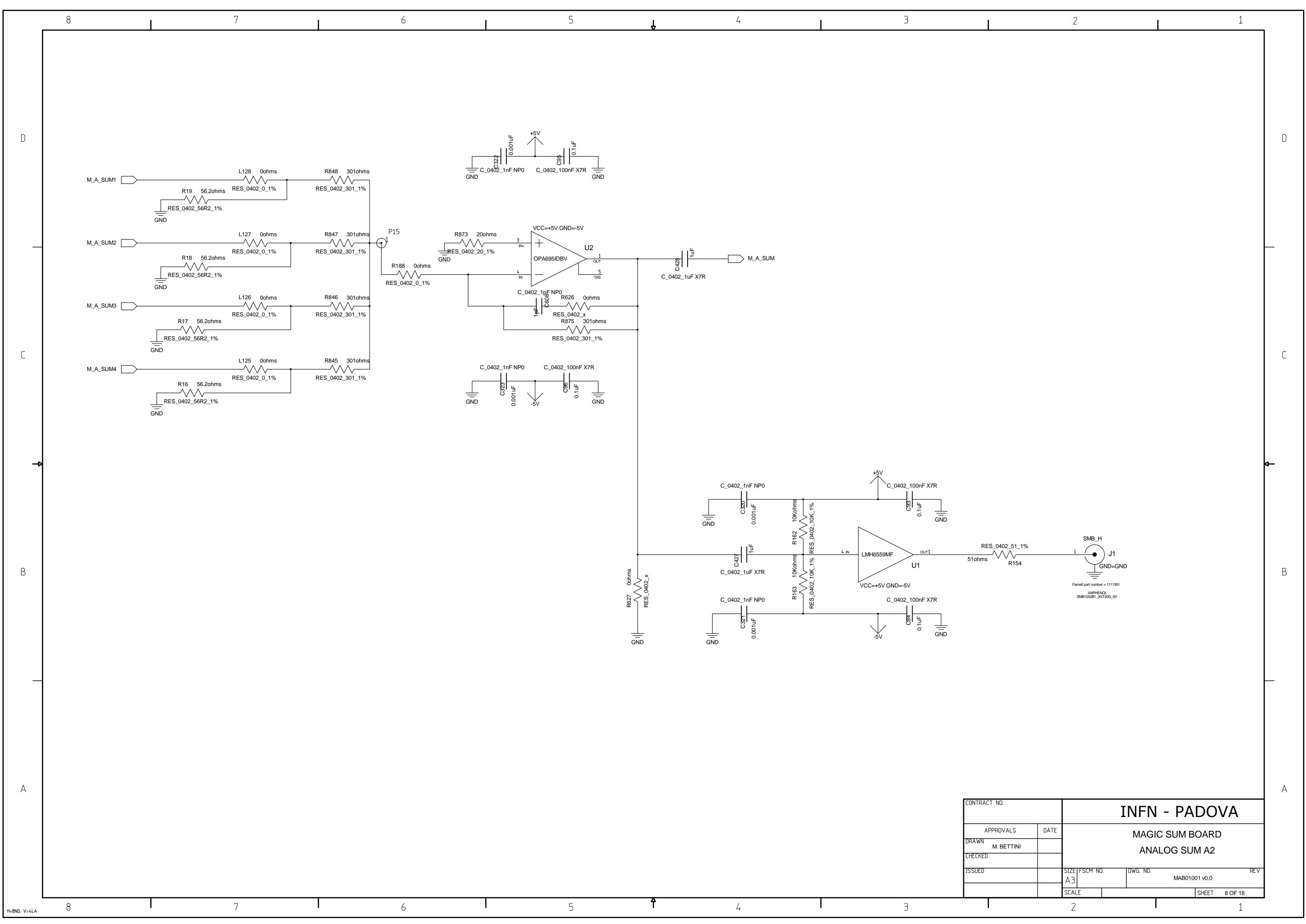

CONTRACT NO.		INFN - PADOVA			
APPROVALS	DATE				
DRAWN	M. BETTINI	MAGIC SUM BOARD ANALOG SUM A2			
CHECKED					
ISSUED		SIZE	FSCM NO.	DWG. NO.	REV
		A3		MAB01001 v0.0	
		SCALE		SHEET	8 OF 18

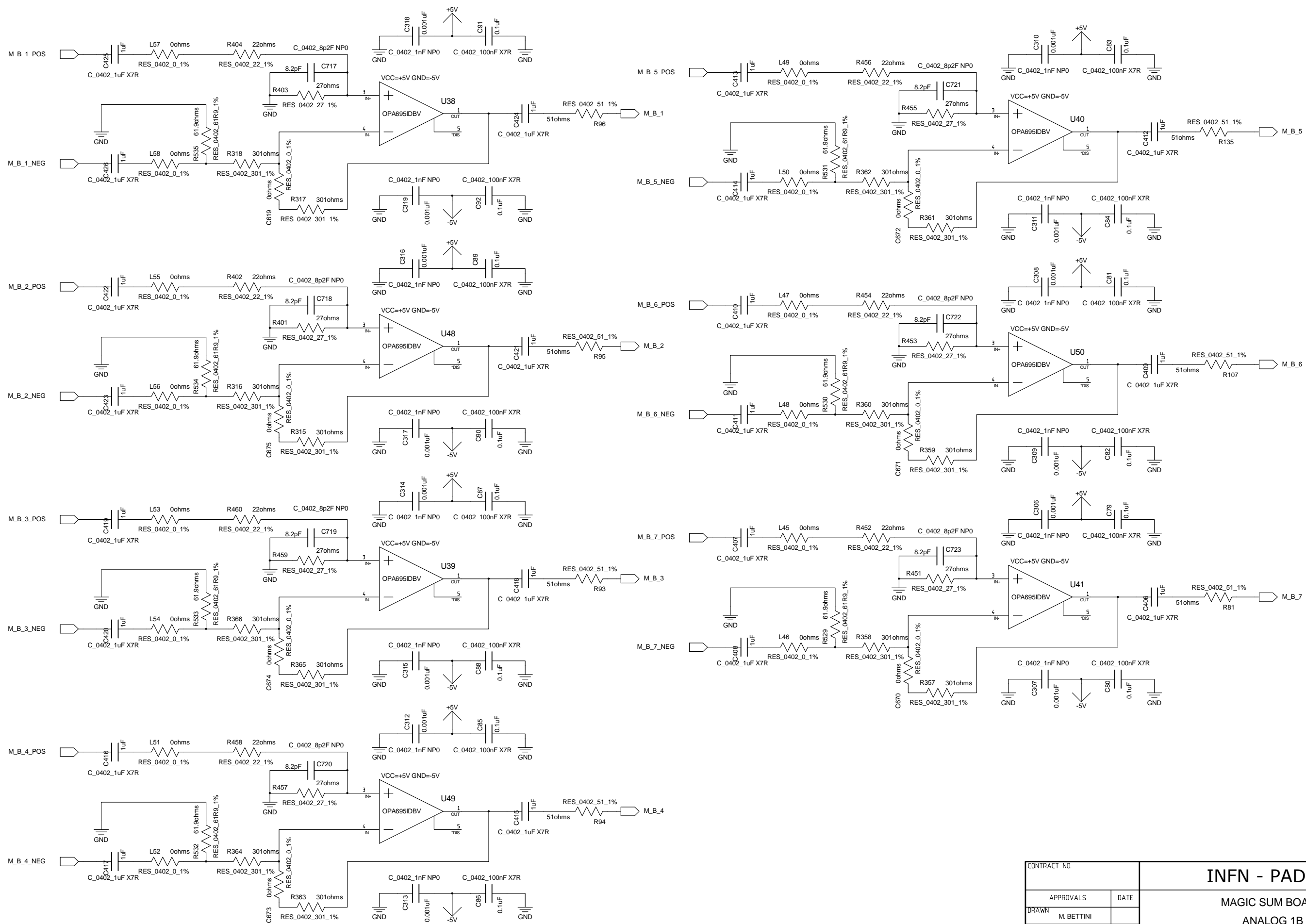

CONTRACT NO.		INFN - PADOVA	
APPROVALS	DATE		
DRAWN	M. BETTINI	MAGIC SUM BOARD	
CHECKED			
ISSUED		SIZE	FSCM NO.
		A3	
		DWG. NO.	REV
			MAB01001 v0.0
		SCALE	SHEET 9 OF 18

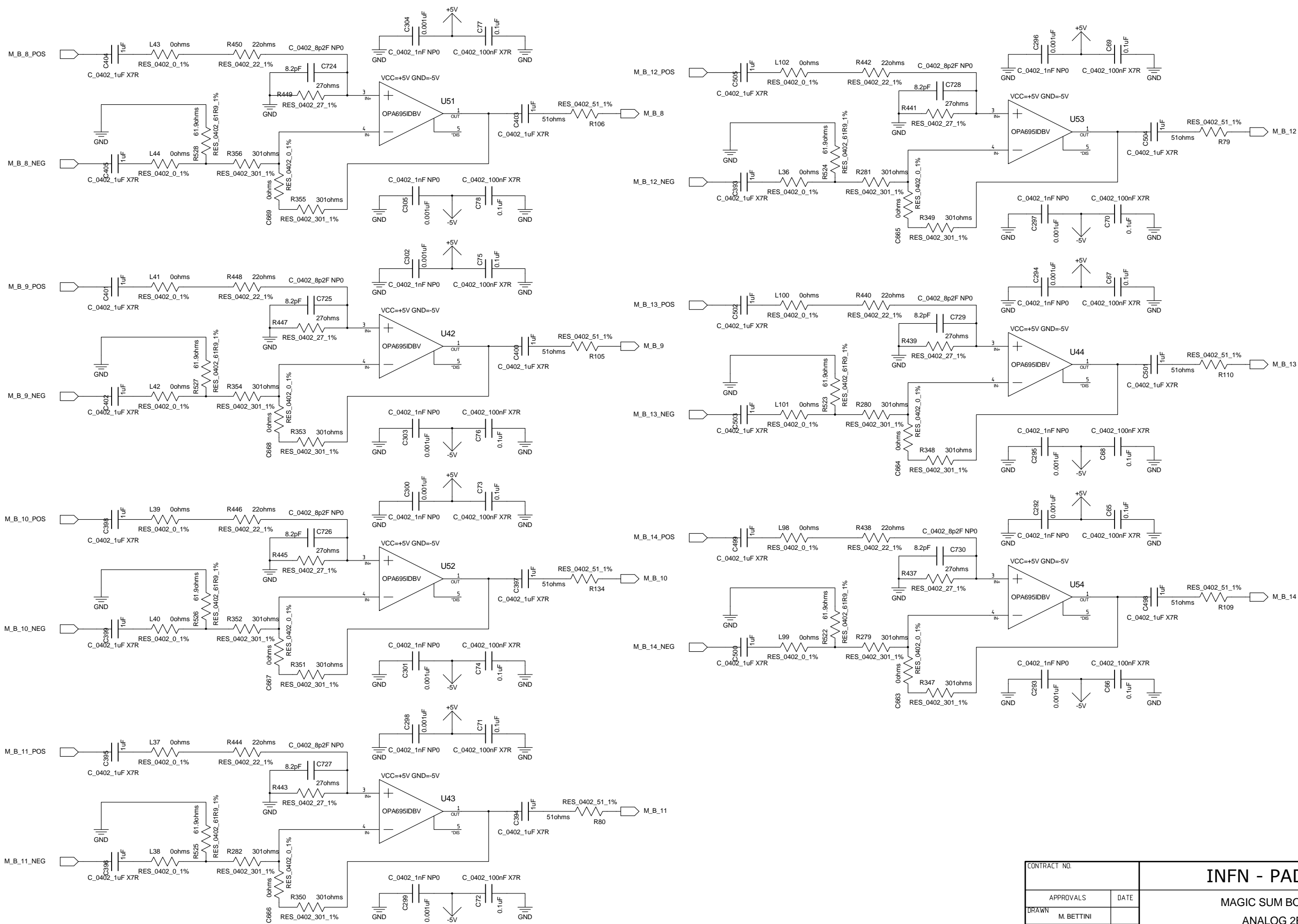

CONTRACT NO.		INFN - PADOVA	
APPROVALS	DATE		
DRAWN M. BETTINI		MAGIC SUM BOARD ANALOG 2B	
CHECKED			
ISSUED		SIZE A3	FSCM NO.
		DWG. NO.	REV
		SCALE	SHEET 10 OF 18

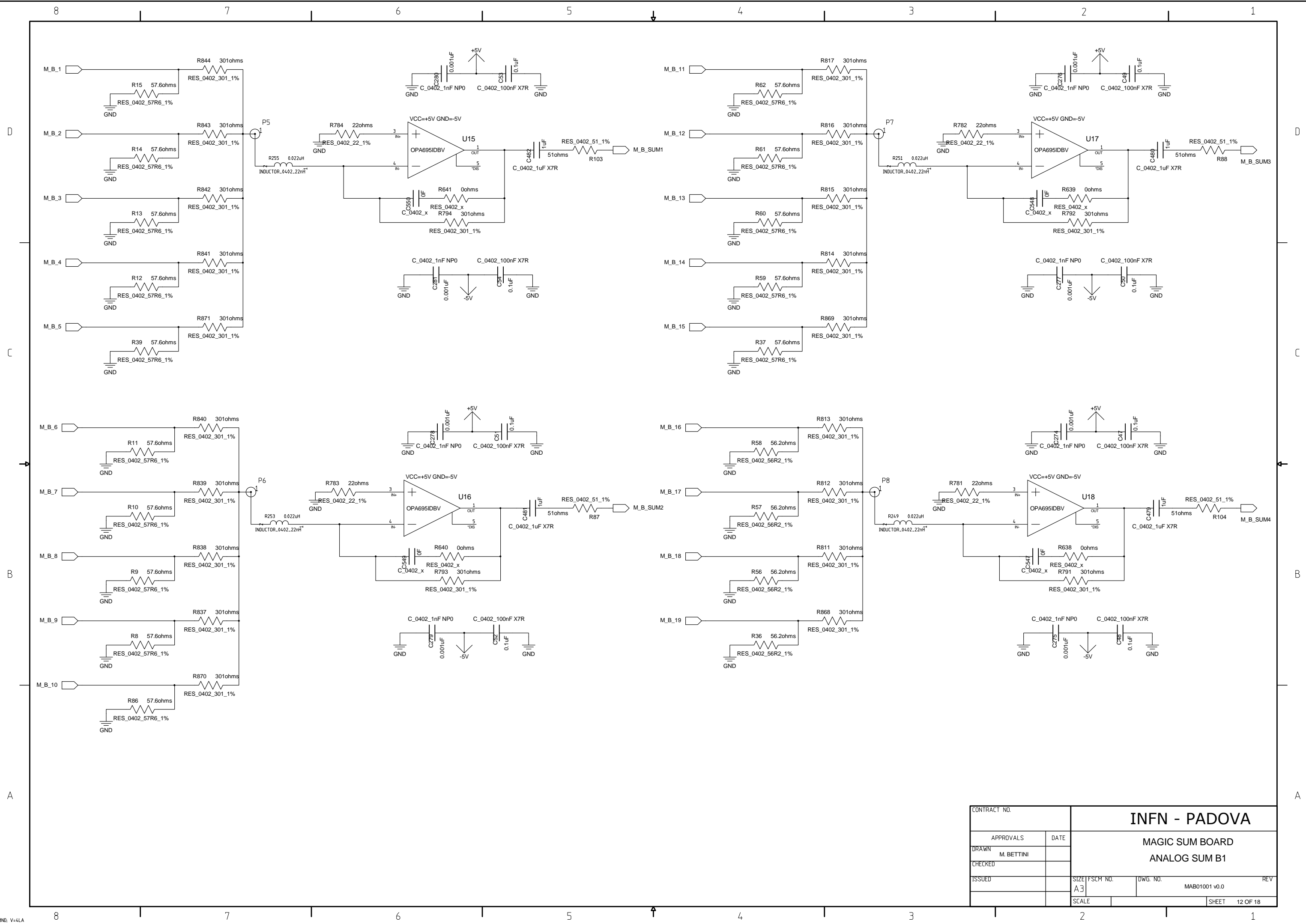

CONTRACT NO.		INFN - PADOVA			
APPROVALS	DATE				
DRAWN	M. BETTINI	MAGIC SUM BOARD			
CHECKED					
ISSUED		SIZE	FSCM NO.	DWG. NO.	REV
		A3		MAB01001 v0.0	
		SCALE		SHEET	12 OF 18

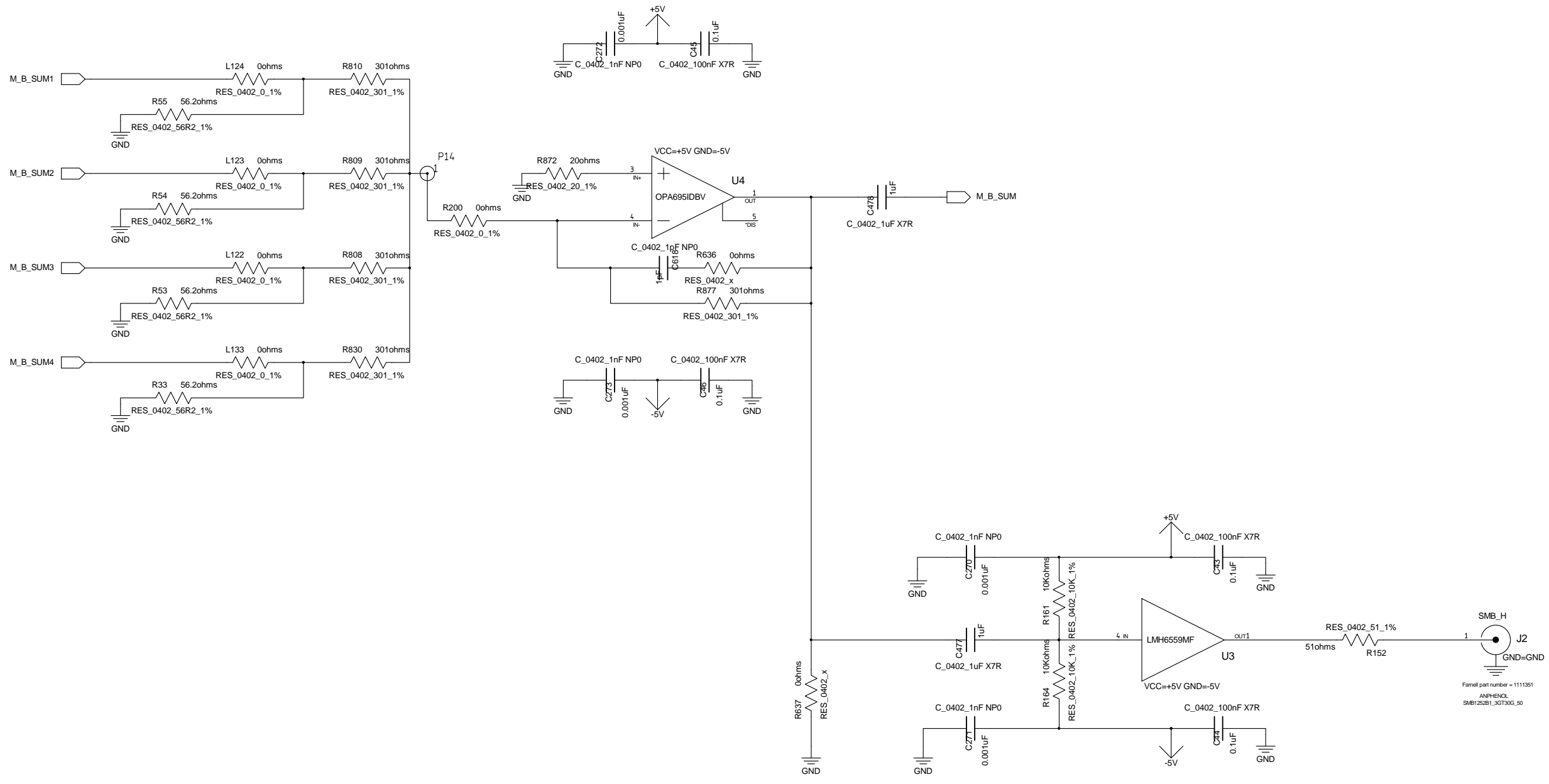

CONTRACT NO.		INFN - PADOVA			
APPROVALS	DATE				
DRAWN	M. BETTINI	MAGIC SUM BOARD ANALOG SUM B2			
CHECKED					
ISSUED		SIZE	FSCM NO.	DWG. NO.	REV
		A3		MAB01001 v0.0	
		SCALE		SHEET	13 OF 18

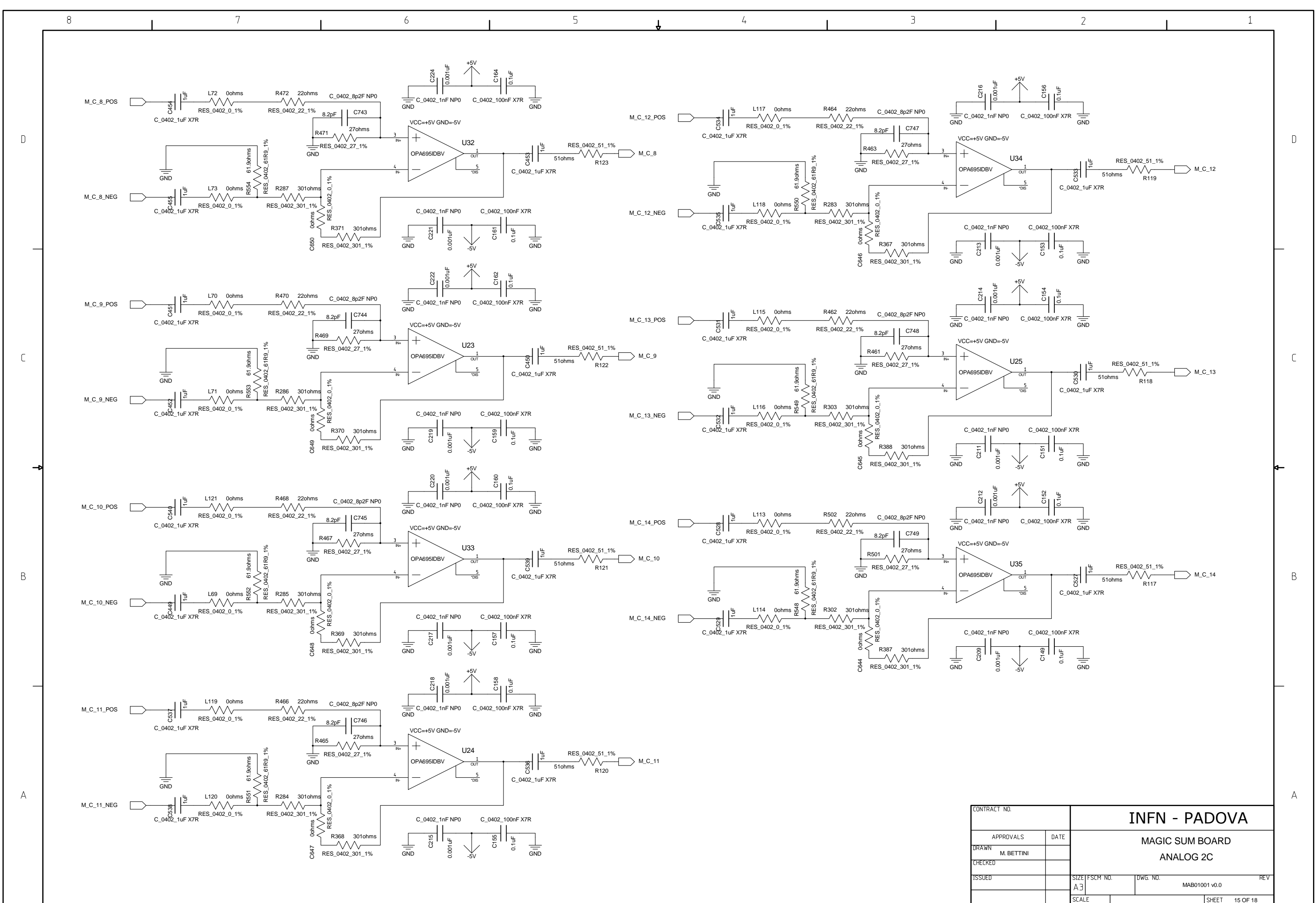

CONTRACT NO.		INFN - PADOVA			
APPROVALS	DATE				
DRAWN	M. BETTINI	MAGIC SUM BOARD			
CHECKED				ANALOG 2C	
ISSUED		SIZE	FSCM NO.		
		A3		MAB01001 v0.0	
		SCALE		SHEET	15 OF 18

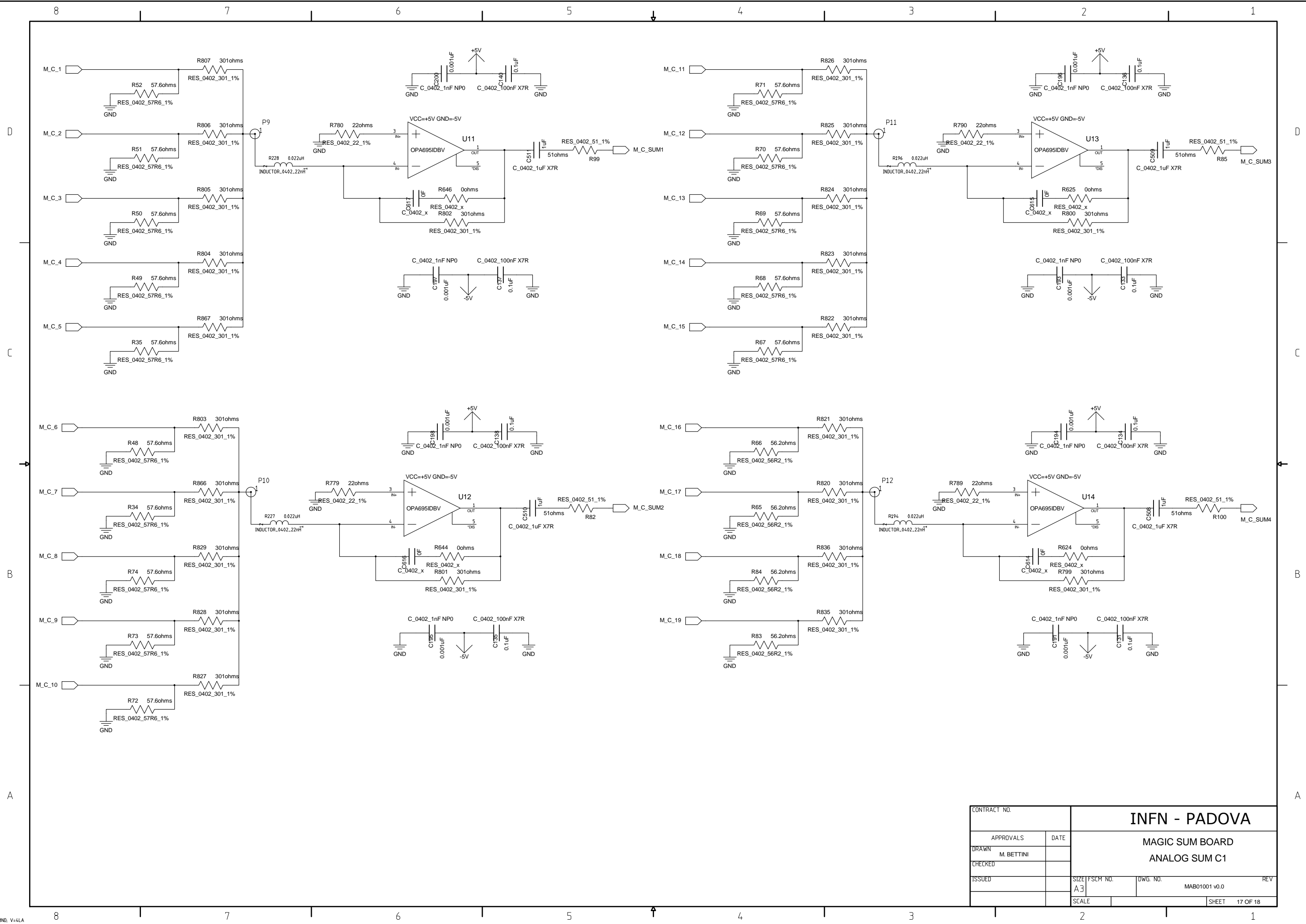

CONTRACT NO.		INFN - PADOVA			
APPROVALS	DATE				
DRAWN	M. BETTINI	MAGIC SUM BOARD			
CHECKED					
ISSUED		SIZE	FSCM NO.	DWG. NO.	REV
		A3		MAB01001 v0.0	
		SCALE		SHEET	17 OF 18

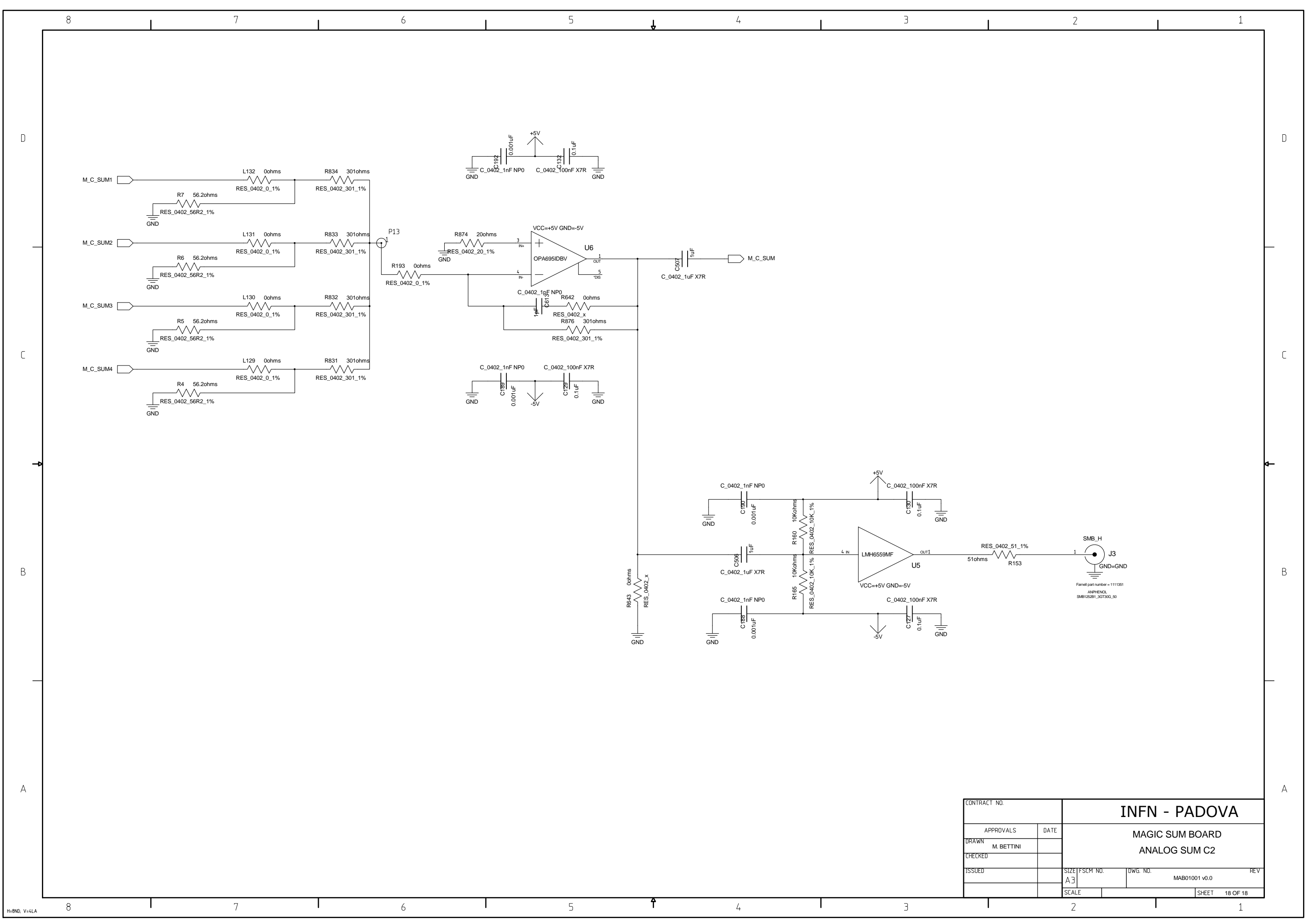

CONTRACT NO.		INFN - PADOVA			
APPROVALS	DATE				
DRAWN	M. BETTINI	MAGIC SUM BOARD ANALOG SUM C2			
CHECKED					
ISSUED		SIZE	FSCM NO.	DWG. NO.	REV
		A3		MAB01001 v0.0	
		SCALE		SHEET	18 OF 18

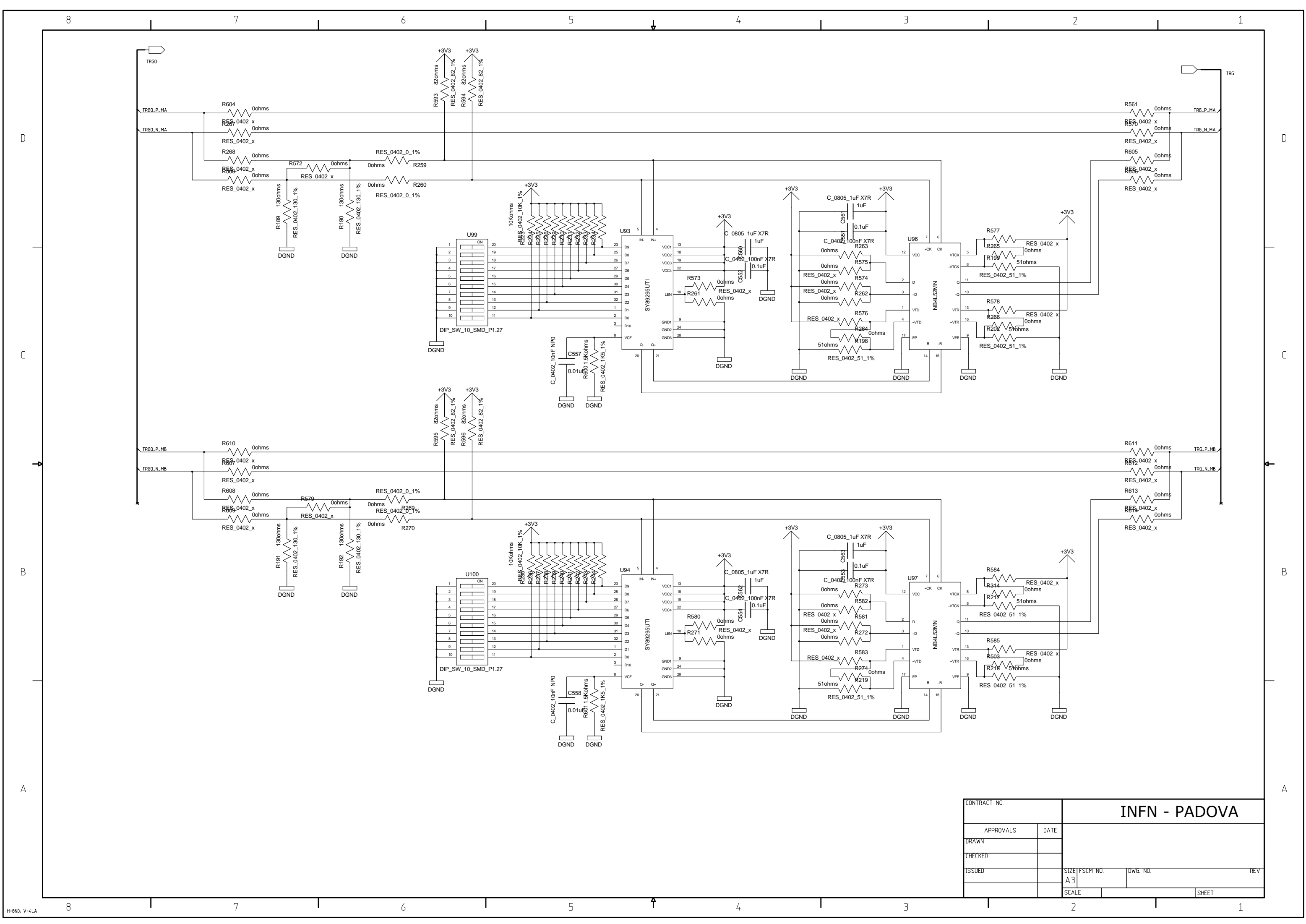

CONTRACT NO.		INFN - PADOVA	
APPROVALS	DATE		
DRAWN			
CHECKED			
ISSUED		SIZE FSCM NO.	DWG. NO.
		A3	
		SCALE	SHEET

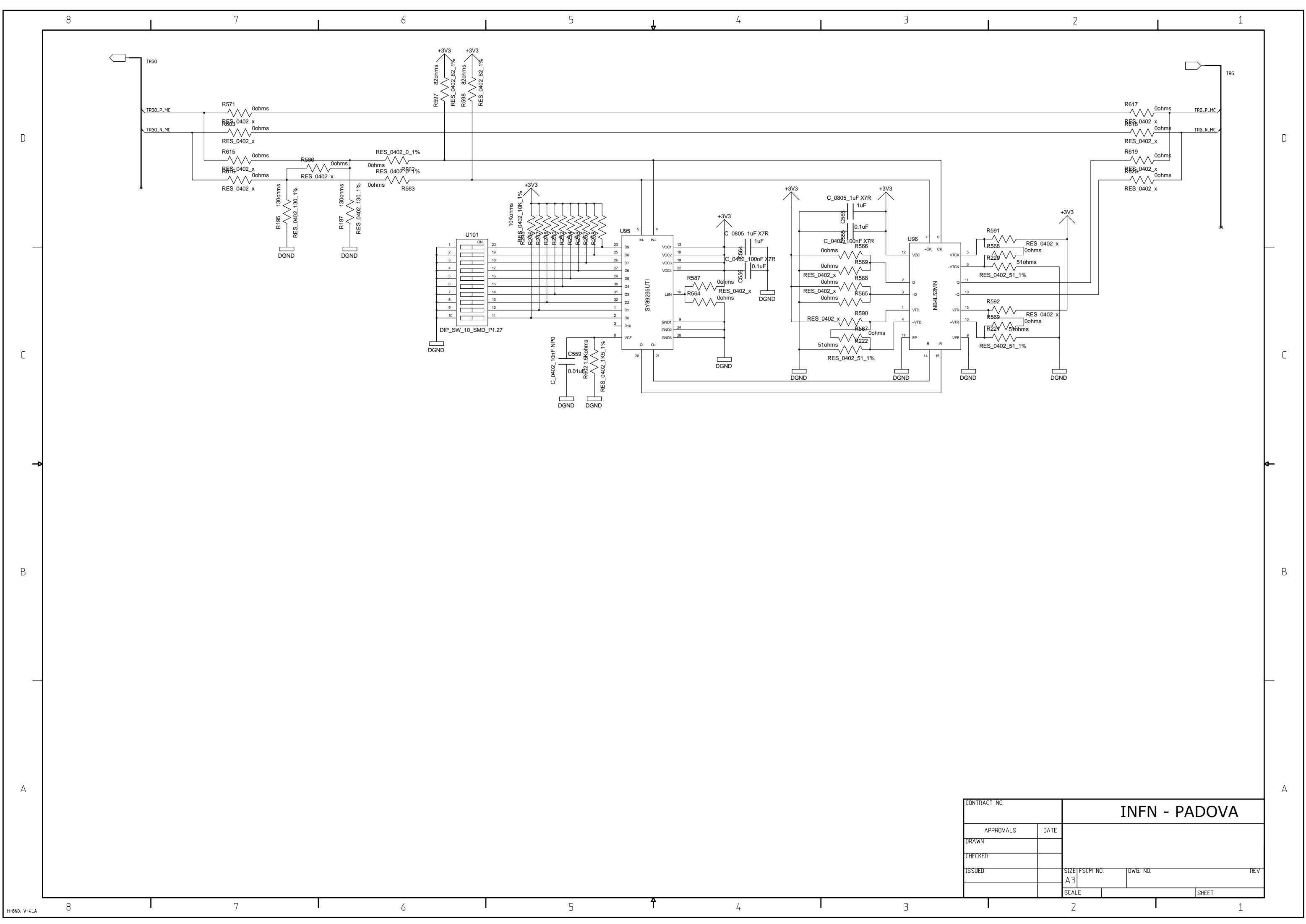

CONTRACT NO.		INFN - PADOVA		
APPROVALS	DATE			
DRAWN				
CHECKED				
ISSUED				
		SIZE FSCM NO.	DWG. NO.	REV
		A3		
		SCALE	SHEET	